

Turmdrehkran 13 HM

Tower Crane / Grue à tour / Gru a torre / Grúa torre
Guindaste de torre / Башенный поворотный кран

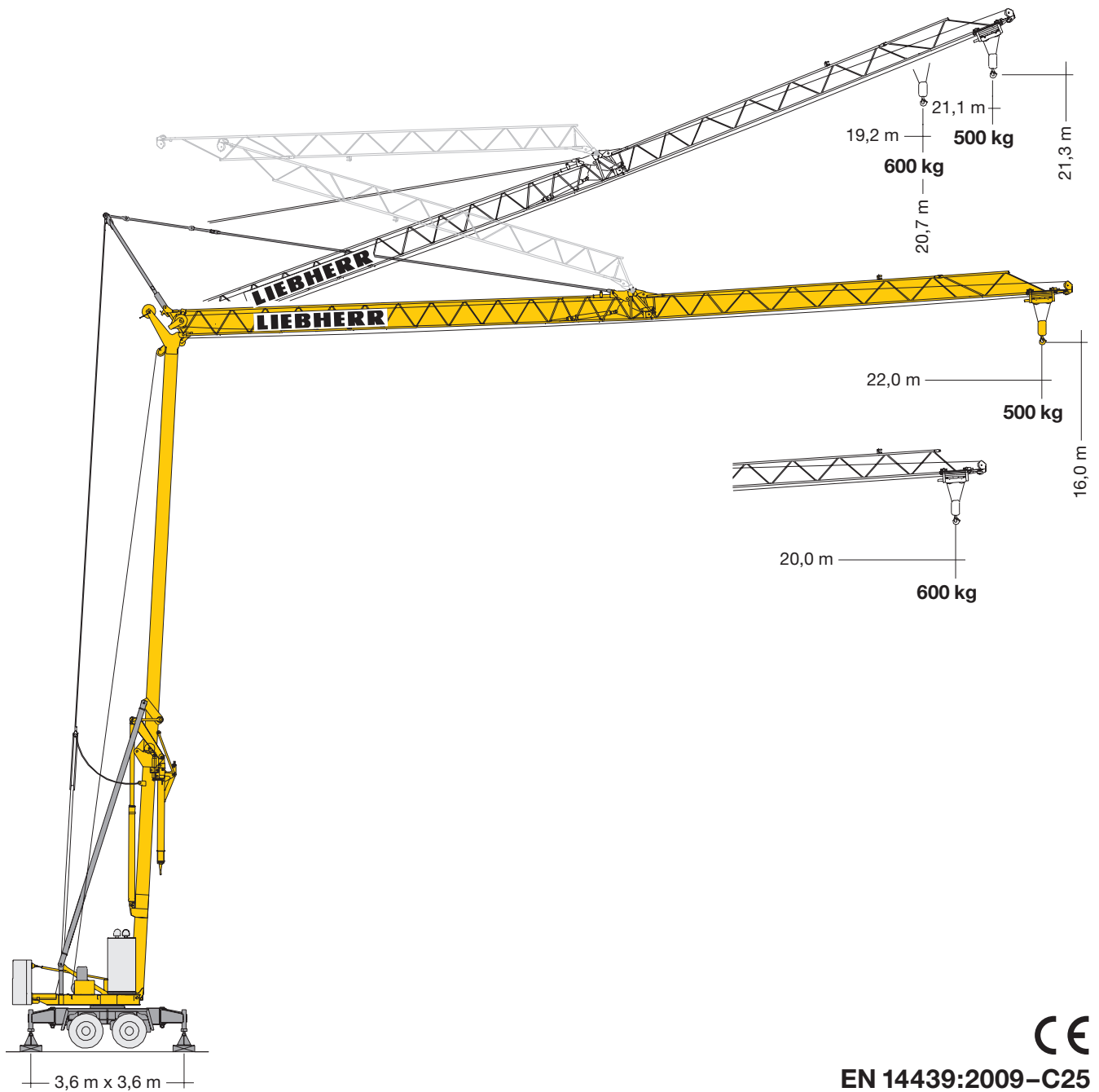

LIEBHERR

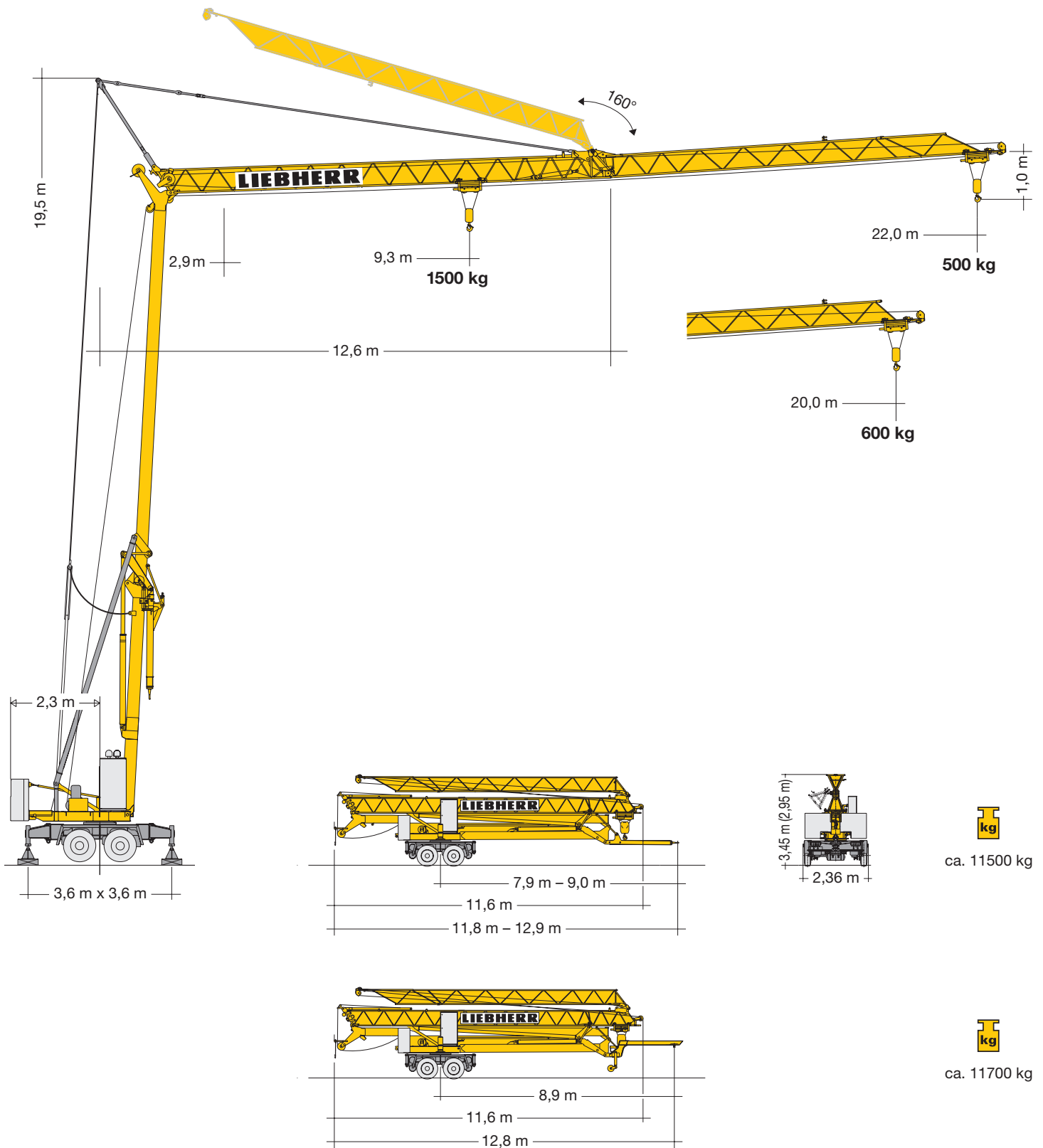

Gewicht Weight / Poids / Peso / Peso / Pesos / Macca

	1 x 4600 kg	r = 2,3 m		6600 kg
--	-------------	-----------	--	---------

Ausladung und Tragfähigkeit

Radius and capacity / Portée et charge / Sbraccio e portata
Alcances y cargas / Alcance e capacidade de carga / Вылет и грузоподъемность

m	m / kg	m/kg												
		10,0	11,0	12,0	13,0	14,0	15,0	16,0	17,0	18,0	19,0	20,0	21,0	22,0
22,0	2,9-9,3 1500	1360	1200	1080	970	890	810	750	690	650	600	570	530	500
20,0	2,9-9,7 1500	1440	1270	1140	1030	940	860	790	740	690	640	600		
11,6	2,9-10,4 1500	1500	1390	1300										

Auslegersteilstellung 20°

Elevated jib 20°
Flèche inclinée 20°
Braccio inclinato a 20°
Pluma inclinada 20°
Lança inclinada 20°
Положение стрелы под углом 20°

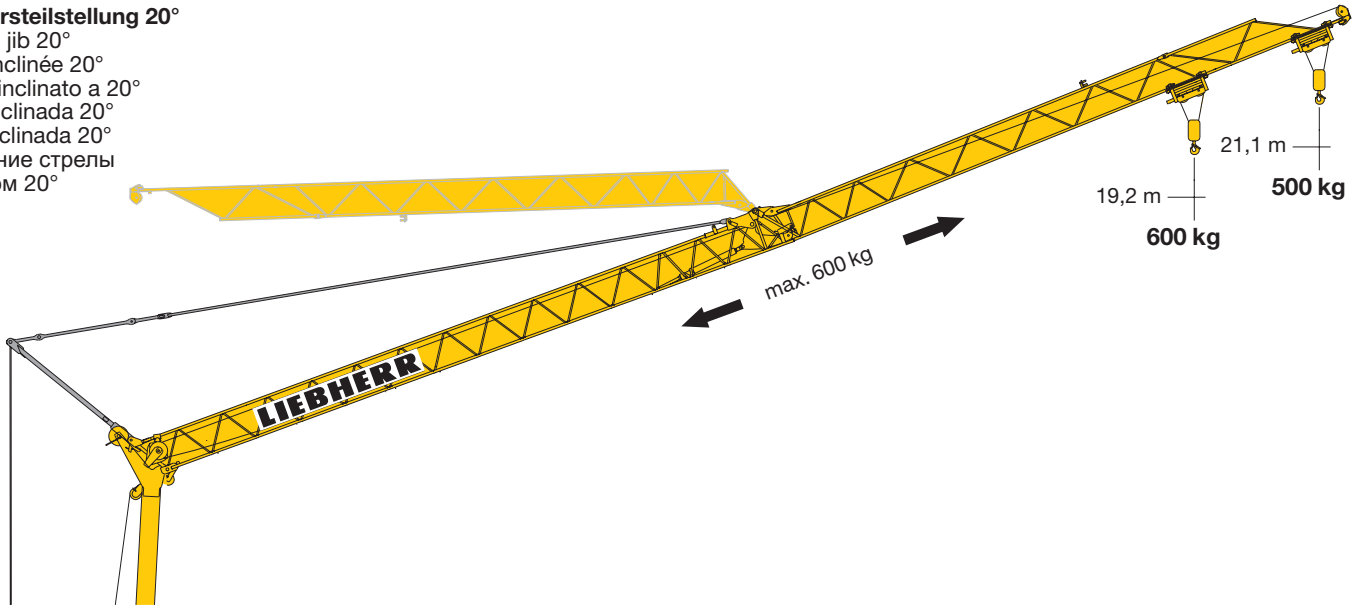

Antriebe

Driving units / Mécanismes d'entraînement / Meccanismi / Mecanismos / Mecanismos / Приводы

	230 V	400 V	
	U/min 0 ↔ 1,0 sl./min tr./min	U/min 0 ↔ 1,0 sl./min tr./min	1,1 kW FU
	6,0 ↔ 12,0 m/min	12,0 / 24,0 m/min	0,6 / 1,2 kW
	ca. 160°/min.	ca. 160°/min.	3,0 kW

	Stufe / Step / Cran / Marcia		
	Velocidad / Velocidade	kg	m/min
3,5 kW	230 V FU		
	1	1500	2,5
	2	1500	5,0
	3	750	10,0
	400 V KL		
	1	1500	4,0
	2	1500	12,5
	3	750	25,0
	400 V FU		
1	1500	2,5	
2	1500	12,5	
3	750	25,0	

BGL		C.0.05.0012
-----	--	-------------

	230 V	Hz	A
30,0 m	3 x 2,5 mm ²	50	16,0

	400 V	Hz	kVA
100,0 m	5 x 4 mm ² KL/FU	50	8,0

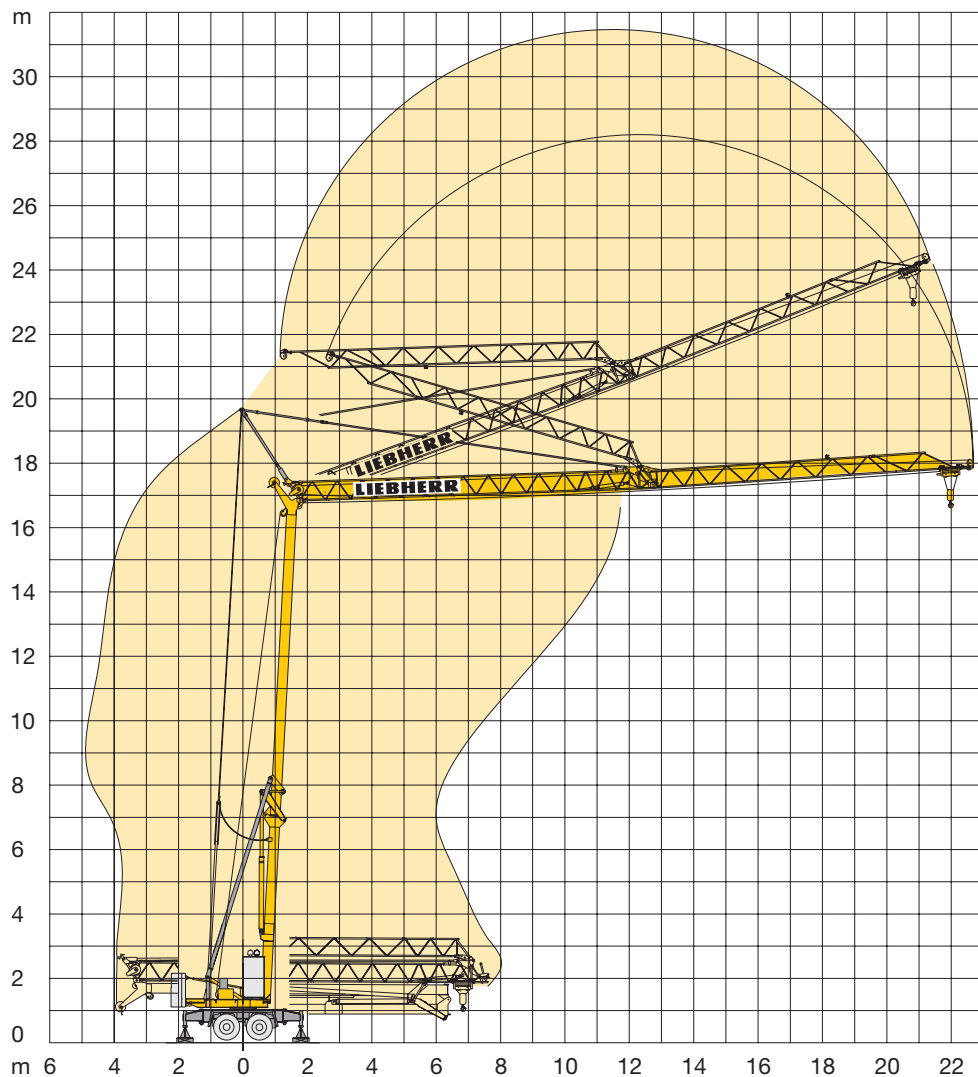

Kolli-Liste

Packing List / Liste de colisage / Lista dei colli
 Lista de contenido / Lista de embalagem / Упаковочный лист

Pos. Item Rep	Anz. Qty. Qte.		L (m)	B (m)	H (m)	kg
1	1	Ausleger-Verlängerung 20,0 m – 22,0 m Jib extension / Rallonge de la flèche / Elemento estensione braccio / Prolongación de pluma Extensão da lança / Удлинение стрелы	3,00	0,71	0,60	35

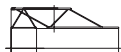

Konstruktionsänderungen vorbehalten! / Subject to alterations! / Sous réserves de modifications! / Riservato il diritto di modifiche strutturali!
 ¡Sujeto a modificaciones! / Salvo modificação da construação! / Права на внесение конструкторских изменений сохраняются!

Sämtliche Angaben erfolgen ohne Gewähr. / This information is supplied without liability. / Ces renseignements sont sans garantie. / Tutte le indicazioni fornite senza garanzia. / Declinamos toda responsabilidad derivada de la información proporcionada. / Declinamos qualquer responsabilidade quanto à informação fornecida. / Все данные указаны без обязательств.

120 P – 5803 • EN 14439:2009 – DIN 15018-H1/B3 • BGL C.0.05.0012 • 0.10 / 7

Printed in Germany.